

rausch

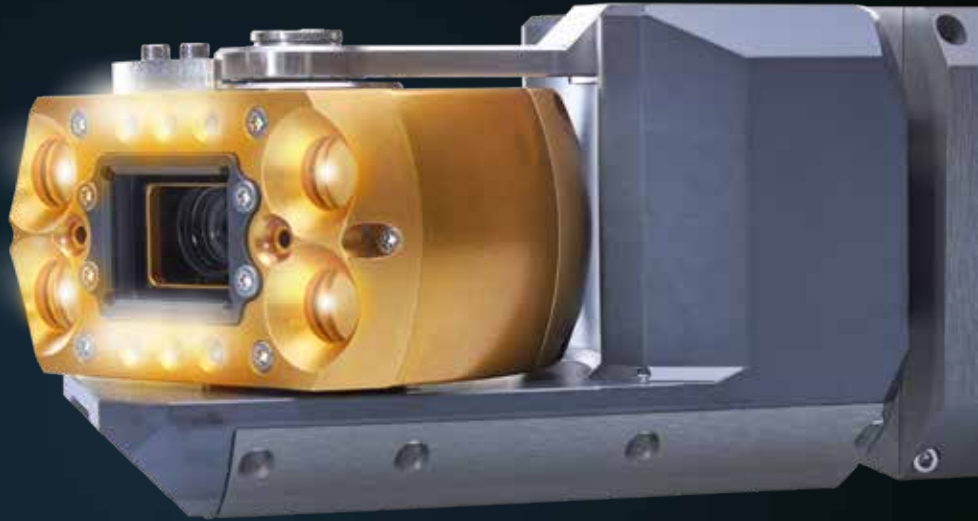

DART
SYSTEMS

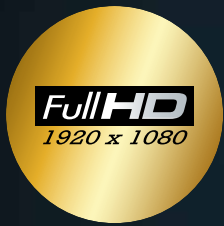

rausch
REHAB



**WE ARE UNIQUE.
WORLDWIDE.**

The companies operating under the umbrella of RAUSCH INTERNATIONAL GROUP are, Rausch GmbH, minCam GmbH, Rausch Rehab GmbH, Dart Systems Ltd and Rausch Electronics LLC, they develop and produce innovative products in the field of CCTV inspection systems and Leak testing systems, Cutters and UV curing technology for liners, all to enhance optical pipe and sewer inspections and trenchless sewer rehabilitation. The perfectly coordinated technologies aim to keep the most valuable infrastructure, the sewage network, in good working order, to prevent negative influence to the environment and people.



Innovative technology saves the environment

Content

04 RAUSCH-GMBH	26 Software
05 Sewer inspection	28 Pallon – AI in sewers
06 Mainline sewer inspection 100 – 600 mm	30 Accessory
08 Mainline sewer inspection 135 – 3000 mm	31 Shaft inspection
10 M series: Lateral launch system	32 DART SYSTEMS LTD
13 Lateral tracking system	34 Inspection camera systems
14 Additional components	35 miCro
16 Product lines	36 DX inspection systems
17 Rausch-Tab	37 Dart Eye Mini
18 Rausch basic	38 RAUSCH REHAB GMBH
20 Rausch mobile	40 UV-Systems
21 Rausch comfort	42 Cutter
22 Rausch premium	
24 Leak test systems	

IMPRINT
 Responsible for the content:
 Rausch International Group GmbH
 Brühlmoosweg 40, 88138 Weißenberg
 +49 8389 898-0, info@rausch.international
 www.rausch.international
 CEO: Stefan Rausch, Hans Kjärsgård
 Konzept and design: steigenberger.li
 Pictures: © Marco Mehl, fotograf-ravensburg.de
 Rausch International Group

RAUSCH IS THE FUTURE – AND THE FUTURE IS NOW

High-resolution, precise, modular, and efficient - Rausch sets new standards in sewer inspection and control technology. Rausch's developments ensure inspections at the highest level, in pipe systems from 50 to over 3000 mm. They are the result of company spirit, to invent, consistent progress and adaptation of proven systems to current market requirements. Razor-sharp images of the world's first transmission in full HD quality with copper cables without optical fibers, promise inspections at the highest level. The result: razor-sharp image quality, perfect recording, and documentation of the inspection, easy to handle, simple service, minimized maintenance costs. Vehicles with a wheelbase of 3,600 mm achieve a total weight of only 3,100 kg, even when fully built out, thanks to lightweight construction with innovative honeycomb technology.

rausch

Efficient Inspection

Mainline sewer inspection
100 – 600 mm



Option:
Atex



Measuring function

Thanks to integrated laser diodes, the digital pan and tilt camera KS 60 is in addition capable of doing a precise diameter and damage measurements.

COMBINATION



Crawler FW 90

- 100 – 600 mm
- 3 drive axles
- Manuel/automatic steering function
- Continuously adjustable automatic reversing mechanism
- 30° bends from 150 mm
- Camera quick connect
- Mechanical camera high adjustment
- Electric lifting gear
- Rear view camera
- Tilt sensor
- Temperature measurement
- Additional lighting
- Continues internal pressure check



Camera KS 40

- From 75 mm
- Resolution: over 420 TV lines
- 90° bends from 90 mm
- Attachable pin
- 33 kHz and 512 Hz locating
- Robust lens module without moving parts = Liquid lens
- 2 laser diodes for precise measurement
- Manual and automatic focus
- Integrated 3D sensor
- Continues internal pressure check

Camera KS 60

- 100 – 600 mm
- Pan and tilt camera
- Resolution HD: 1920 x 1080 Pixel
- Resolution SD: over 530 TV lines
- Manual and automatic focus control
- 2 laser diodes for measurement
- Multiple zoom
- Integrated positioning: 33 KHz und 512 Hz
- Integrated 3D sensor
- Continues internal pressure check



Modular Inspection

Mainline sewer inspection
135 – 3000 mm

The crawler FW 135 is the bases for mainline sewer and lateral launch inspection with only one crawler from 135 up to 3000 mm.



Option:
Atex



COMBINATION



Crawler FW 135

- 135 – 1600 mm
- Extension with Lafette up to 3000 mm or 118"
- Manuel/automatic steering function
- Continuously adjustable automatic reversing mechanism
- Camera quick connect
- Electric lifting gear
- Rear view camera
- Tilt sensor
- Temperature measurement
- Continues internal pressure check
- Option: M series

Camera KS 135



- 135 – 3000 mm
- Pan and tilt camera
- Resolution HD: 1920 x 1080 Pixel
- Resolution SD: over 530 TV lines
- 2 laser diodes for precise measurement
- Zoom: 10x optical
- Wireless additional lighting
- Option: variable camera head turning speed for deformation measurement
- Lens with automatic diaphragm, auto focus, manual focus
- Continues internal pressure check

Deformation measurement

- Option scanning function:
- Deformation measurements of complete reaches with visual representation of the deformations
 - Selective evaluation of deviations
 - Determining the diameter

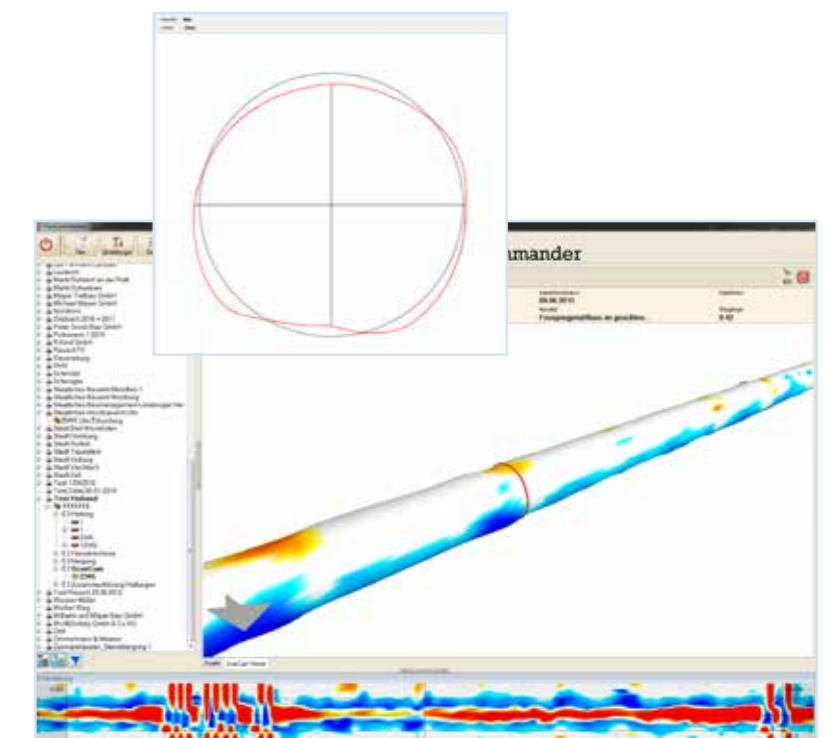

M series

from 150 mm



With the M series, CCTV inspections of mainlines as well as building connection lines can be conducted from the mainline in one single operation.



Integrated LATRAS sensor

Option: **Atex** 

As an option, all modules of the M series are available in Ex-protection version according to directive 2014/34/EU.

Option: HD
Complete M serie also available in HD: KS 60 HD, KS 135 HD, PKM 200 HD.

COMBINATION



Satellite system with PM 135

- 150 – 1200 mm
- Crawler FW 135 with electrical lifting gear forms the bases
- Pan and tilt camera KS 40 and KS 60
- Inspection of building connections
- Observation and positionierung camera ZKM 135
- Cable feed module SKM 135
- Tilt and positioning module PM 135

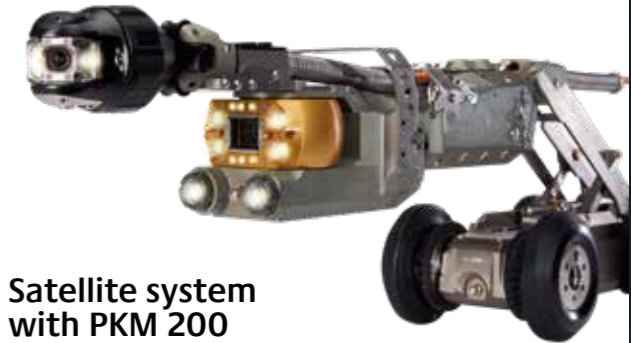

Satellite system with PKM 200

- 200 – 1800 mm
- Crawler FW 135 with electrical lifting gear forms the bases
- Pan and tilt camera KS 40 and KS 60
- Inspection of building connections
- PKM 200 to ensure the exact positioning of the lateral launch camera and inspects mainlines from 200 mm



Additional components



Jetting system

Parallel cleaning and inspections of the lateral connection directly from the mainline.



Dual jetting system

The dual jetting system of the M series for cleaning latteral connection before the inspection.

M series

from 150 mm

With the modular concept of the M series, the crawler FW 135 can cope with all challenges and demands of lateral launch.

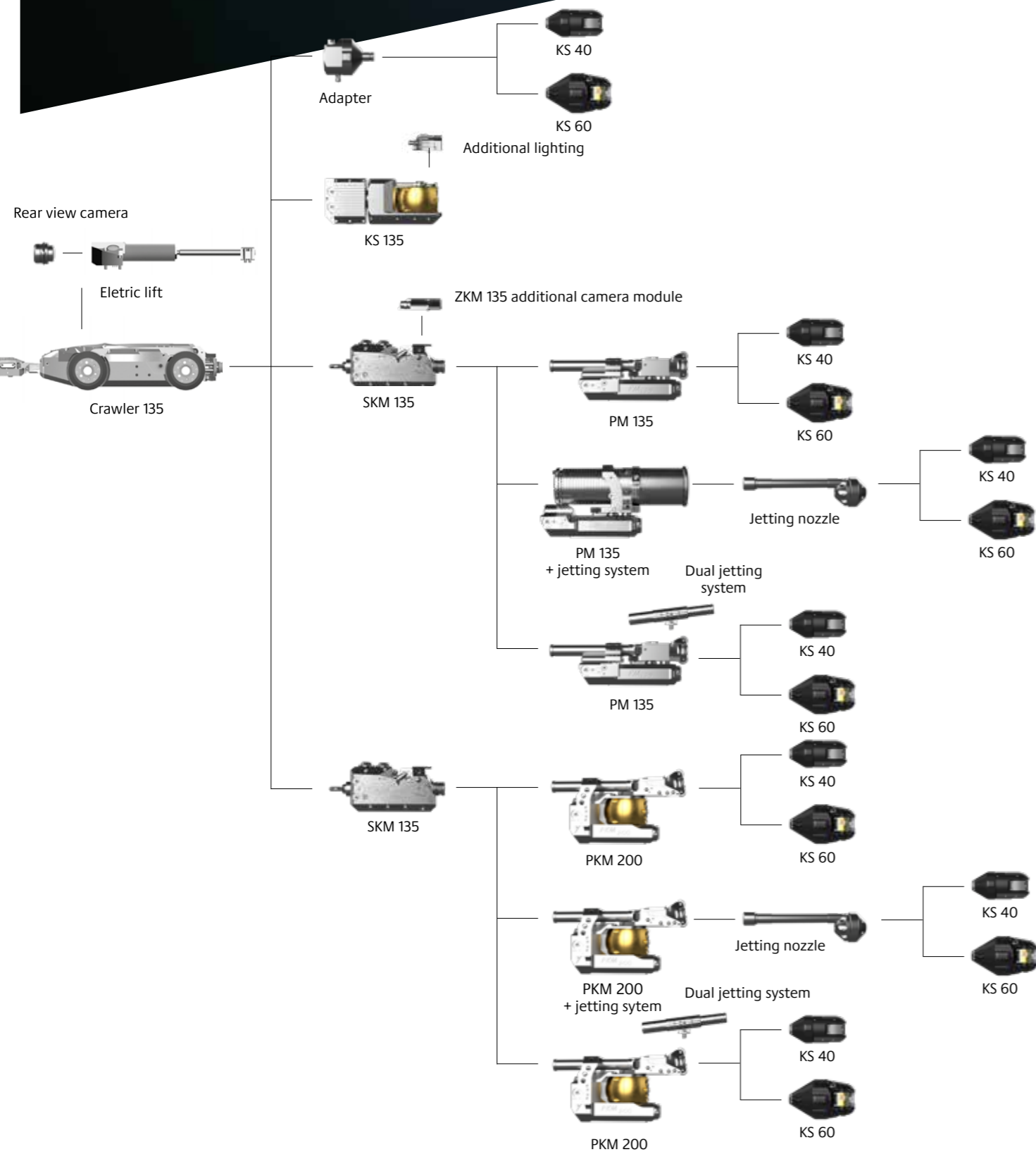

LATRAS

3D inspection with integrated sensor in the camera head

This sensor locating system for automatic measurement and graphic display of the pipe routing of lateral connection pipes is used with the proven KS 60 camera with integrated 3D sensor. These xyz coordinates are permanently registered in parallel with the inspection and allow the line routing to be automatically recorded simultaneously and without significant additional effort for the inspector and displayed in the PicoMaps map module.

LATRAS

- Integrated LATRAS sensors in the camera KS 40 and KS 60
- Feed technology with push or flush operation possible
- Determination of direction and inclination angles
- Distance measurement via incremental encoder with an error accuracy of less than 0.5%
- Online progress measurement in PicoMaps with xyz coordinates
- Measurement recording possible during forward and reverse travel
- Recalibration of the measurement result via endpoint determination
- Location probe optional with transmission frequency of 512 Hz or 33 kHz
- Operation on Rausch satellite systems
- Push operation possible
- Operation on Omicron possible

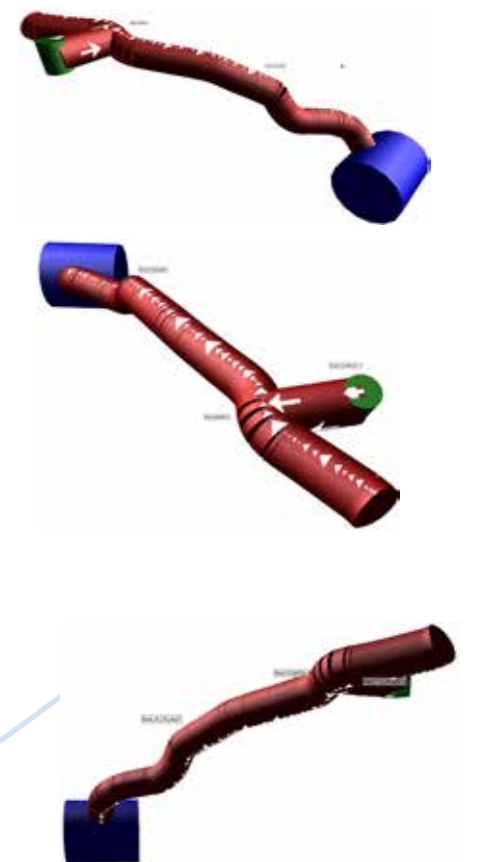

Interactive 3D view possible. Three examples above.

Additional Components



Lafette
For inspections up to 3000 mm



camera raft
Application range from 600 mm for transporting a KS 135 through large water-bearing profiles.



Adapter, main cable
Used for walk-in sewers with optional audio transmission. Multifunctional for shaft inspection and camera raft mounting.

Accessories



Attachment for egg shaped profile
from 200/300 mm up to 900/1350 mm



Rear view camera
Application range from 150 mm



Additional weights
from 150 mm 1,5 kg
from 250 mm 6,6 kg



Wheels
Suitable wheels for all pipe diameters and conditions.



Lowering/lifting hook
For easy insertion of the crawlers into the sewer.



Height extension
For centered camera position with larger diameters.



Electrical lifting gear
Continuous camera positioning from 150 mm.



Quick connect
The camera system can be changed in the shortest possible time using a wireless quick-release technology.



KS 60 Adapter
For mounting the KS 60 camera on the 135 crawler.

Product lines

Rausch basic

Mobile system push and drive



+ Rausch-Tab

Rausch mobile

Mobile electric cable drum with 300 m camera cable



+ Rausch-Tab

Rausch comfort

Van build-system with telescopic swivel arm and chain winch



+ Rausch-Tab

Rausch premium

Van build-premium system in FULL-HD



Rausch-Tab

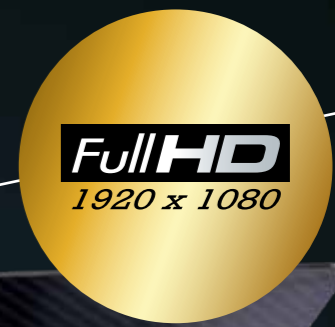

Rausch-Tab

- 12.1" touch screen display
- Integrated PC
- Operating system: Windows 10
- Multifunctional joysticks
- Easy to remove for office work
- Standard basic software for image, video and PDF creation
- Expandable with fully integrated inspection software PipeCommander or any other third-party-system
- Bracket for mounting on the cable drum Omicron, Cubix 300 or vehicle installations
- Wi-Fi capable, LAN capable, USB, HDMI
- Determining the diameter
- Inclination, temperature and laser measurements with internal PC
- Deformation measurement across the entire reach
- Dimension: 410 x 250 mm
- Type of protection: IP 64
- Control unit for Omicron Cubix 300, Elka 6
- Mobile solution for main lines and lateral inspection in Full HD
- Remote service check
- Option: external joysticks

Rausch Basic

Omicron push + Omicron drive
from 50 mm



Option:
Atex

OMICRON

The Omicron combines two worlds in one TV inspection system and is the first system in the world in full HD for pipe and sewer inspections in push and crawler operation.

- Mobile system with compact transport dimensions
- Removable basket with quick release fastener as well as the simple quick-change system of the wheels support purposeful, effective working
- Thanks to the variable folding option and rotating capability of the holder, the Rausch-Tab can be optimally adapted to the operating conditions
- The foldable handle and the skids for stairs make the Omicron easy to handle
- Rechargeable battery operation with exchangeable battery
- Mains adapter

Omicron crawler operation

- Crawler operation from 100 mm
- Crawler FW 90
- Camera KS 40 und KS 60
- Up to 200 m camera cable
- Manuel guidance
- Crank handle
- Path length measurement in mm resolution
- Continues internal pressure check



Omicron push mode

- Push mode from 50 mm
- Pan and tilt camera: KS 40, KS 60
- Axial view camera: SAT 42 with horizontal picture
- Up to 80 m push cable
- Path length measurement in mm resolution
- Expandable with LATRAS for pipeline route measurement
- Determining the diameter
- Continues internal pressure check



Rausch Mobile

100-3000 mm

CUBIX 300

- Rausch-Tab
- Electric cable drum with up to 300 m camera cable
- Control panel with status display
- Foil buttons for the operation from the rear area
- Electric and manual brake
- Remote control
- Cross guide spindle and folding arm
- Continues internal pressure check
- Option: Radio remote control
- Dimension: 425 x 425 x 480 mm
- Weight: 67 kg incl. 300 m camera cable



Rausch Comfort

100 - 3000 mm

Telescopic Swivel arm



ELKA 600

- Up to 300 m camera cable
- Fully synchronized built-in cable drum
- Fully equipped
- Designed for Rausch van builds



Vehicle upgrade



Studio

- Power supply with lithium-ion batteries
- Charging over the standard alternator



Rear area

- Finishing with high-quality aluminum profiles and pull-outs for crawlers and accessories
- Rear monitor
- Folding rain and sun protection canopy
- Water tank for cleaning



Technical details

- Integrated 8" LCD monitor
- LED work light
- Telescopic swivel arm
- Integrated chain winch with 20 metre chain length for lifting and lowering camera and crawler
- Remote control, optional wireless remote control
- Unwind aid
- Electrical & mechanical drum brake

Rausch Premium

CCTV inspections from 100 – 3000 mm
Lateral launch system from 135 – 1800 mm



RCA 4.0

- Full-HD transmission with cooper cable without fibre optics
- Resolution HD: 1920 x 1080 Pixel
- Based on the VML technology specially developed and patented for this purpose
- Elka cable drum with up to 500 m camera cable
- Pressure test: sleeves, reaches, shafts, buliding connection

Result:

- Razor sharp image quality
- Exact recording and documentation of the inspection
- Minimized maintenance costs
- Remote service check

Studio



Technical details

- RCA 4.0 technology in the studio
- Digital video technology in full HD quality
- 1920 x 1080 pixels or MPEG-4 with 720 x 576 pixels
- Ergonomic operating concept with electrical lifting table for fatigue-free working
- System control via industrial PC with a 15" touch screen and two multifunctional joysticks for camera and crawler operation
- User-configurable user interface and joystick operation
- Digital overlay technology for measured value and data display in different national versions
- Display technology, adjustable font sizes and colours
- 24" full HD video monitor
- Serial bus system for the control of the cable drums, crawlers and cameras and the full HD satellite system
- Ethernet-, Wifi- and UMTS connection to the video and data exchange with documentation PC and software (PipeCommander, WinCan or other acquisition programmes)
- Alternatively recording in MPEG-4 possible, if full-HD data sets cannot be processed
- Power supply with lithium-ion batteries

Rear area



Technical details

- Rear area expansion with passage to the studio
- Water supply
- Elka 600 cable drum HD with observation monitor, telescopic swivel arm and chain winch
- Cable length up to 500 m
- Quadro SAT HD cable drum
- Cable length 160 m
- 40 m push cable
- Lateral launch system in full HD
- Kampac hose reel for socket pressure testing
- Premus 600 for the reach test

Options

- Deformation measuring system
- LATRAS line route measurement
- Up to 3000 mm in connection with crawler extension (Lafette) or camera raft
- Lightweight construction for driver's licence Class B up to 3500 kg total weight
- Expansion according to individual customer requirements possible
- Leak test of individual couplings, pipes, shafts and separators

Crawlers and cameras

- Crawler FW 90 and camera KS 60 HD, 100 – 600 mm
- Crawler FW 135 and Camera KS 135 HD, 135 – 3000 mm
- Modulare lateral launch system M serie: Crawler FW 135 with lateral launch system PM 135, PKM 200 and camera KS 60 HD

Leak test

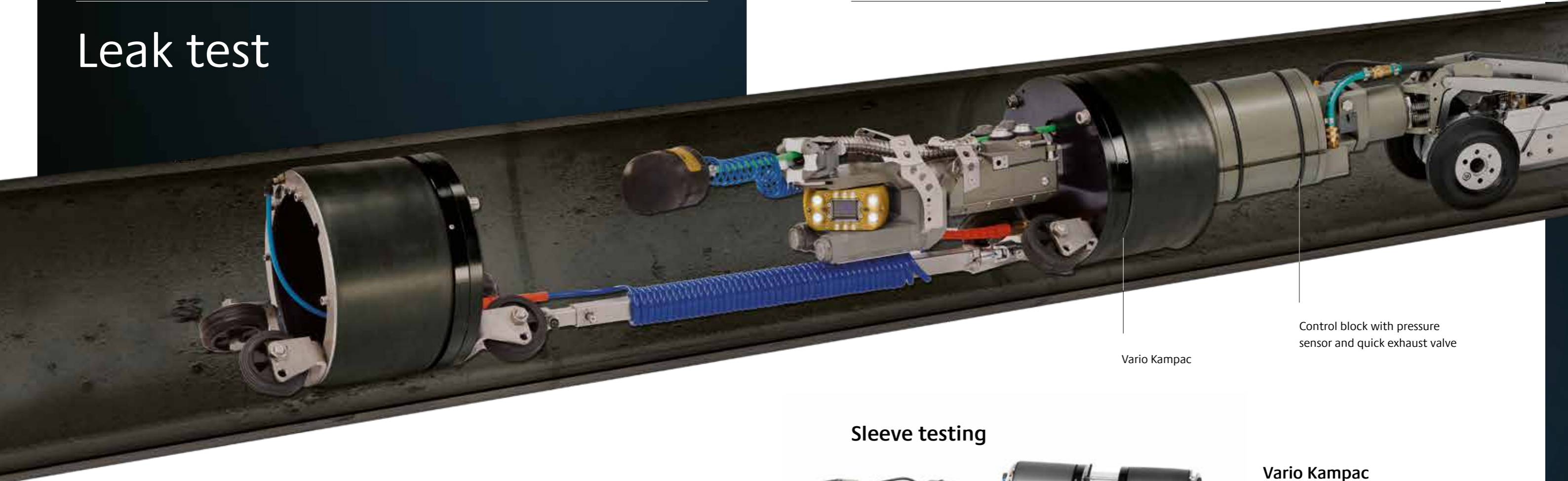

Vario Kampac

Control block with pressure sensor and quick exhaust valve

Premus und Kampac

Our leak testing systems are designed in accordance with national and international requirements.

Depending on your requirements, we offer stand-alone units or we configure a complete installation version. Our PipeCommander software controls, monitors, evaluates and documents all test procedures.



Premus 600

- 70 – 2500 mm
- Vehicle installation version for the reach test
- Test with air and vacuum water, shaft and separator test



Premus 150

- Portable unit for manhole, reach and separator test
- Premus 150 also enables reach tests up to 300 mm
- In addition to shaft and separator testing, analogue to Premus MH

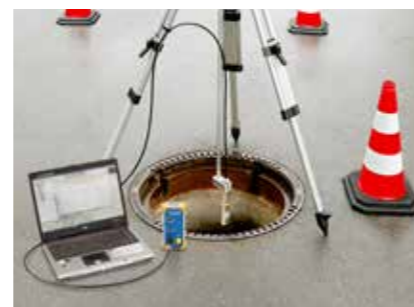

Premus MH

- Portable unit for checking shaft and light liquid separators
- Thanks to the temperature-compensating relative pressure sensor, a highly precise leak test according to DIN 1999 - 100 is guaranteed

Sleeve testing



Kampac

- For single sleeve testing
- 200 – 600 mm
- Pneumatically operated hose drum
- Control block
- Multi-range test packers with lens glasses
- Optionally length: 100 mm or 200 mm
- Test using both air and water
- For positioning a pan and tilt camera is installed
- Variable collar pressure from 1.5 - 4.5 bar
- Quick exhaust valve
- Variable test pressure up to 500 mbar

Vario Kampac

- Leak test of pipe sections and building connection integrations
- 200 – 600 mm
- Test packers are telescopically connected
- Packers are positioned through the modules of the M series
- With the SKM 135 feed module, the shut-off valve is positioned in the building connection and pushed in up to 7 metres

Application ranges

Kampac · Vario Kampac · Premus

Inspection	with
Sleeves	Air and water
Reaches	Air, water or vakuüm
Shafts	Water or vakuüm
Separators	Water
Building connection integrations	Air or water

Sleeve testing system

- With integrated camera
- 100 – 200 mm



Software

Inspection software

PipeCommander

- Innovative features for working as effectively and flexibly as possible
- Vehicle acquisition software
- Office version for administration
- Post-processing and transfer of test data
- Various extensive reporting functions
- With all current guidelines such as IsyBau 2006 and DWA M149-2, based on DIN EN 13508-2
- Common standards such as EN 1610 or DWA A-139 and also DWA M149-6 are supported for leak testing of chambers, pipes and pipe connections
- The DIN 1999-100 and DIN 4040-100 standards apply to the separator test
- The free viewer version lets you easily pass on all inspection data and films to end customers
- All relevant master data and inspection results are recorded
- Datas can be easily edited and exported at any time
- Clear menu structure
- Inspection results can be retrieved in the form of videos, photos, logs and statistics



Facts

- Inspections of reaches, connections and shafts
- Powerful, configurable customer and project management
- Real-time data insertion in the video image of all inspection-relevant data such as video counter, path lengths or damage incidents
- Macro control for camera and crawler
- Hardware-supported image digitization
- Integrated, constantly updated standards and code catalogues
- Free viewer version with all inspection data, images and films
- Configurable report generator for generating detailed reports
- Professional data management: Various project data from PipeCommander and SmartCommander can be imported, merged and edited in the office version.
- Data exchange through IsyBau 96/2001 and IsyBau 2006, 2013 and 2017 interfaces



PicoMaps

- The trend-setting all-rounder for graphical visualization of sewer networks
- Automatically retrieves all available channel network data with geo coordinates from the database
- Visualizes the connection cable progressions from CCTV inspection data - and this in best 3-D quality
- Automated with LATRAS, the locating system for automatic measurement and graphic display of the pipe route of building connection pipes

Details of functions

- Opens cadastral maps as vector drawings suitable for the coordinate space
- Comprehensive sewer network representations based on master data
- Digitalization of manholes, sewer pipes and cables
- Automatic loading and adjustment of corresponding background maps
- Generation of site plans and their display in vector format
- Import of common DXF and SHP file formats
- Position display in UTM or DHDN
- Storage of vector maps (DXF, SHP)
- Free drawing in of objects and lettering

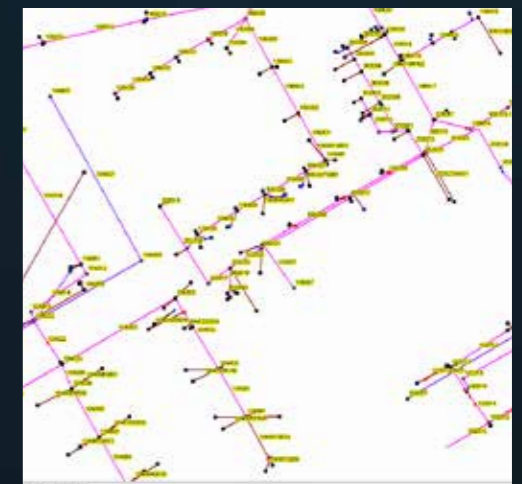

Pallon f.k.a. hades^{AI}

Know the Condition Of Your Sewers and Manholes At the Push of a Button

Pallon is a service that uses artificial intelligence to quickly & objectively report defects in your sewer and manhole inspection footage.

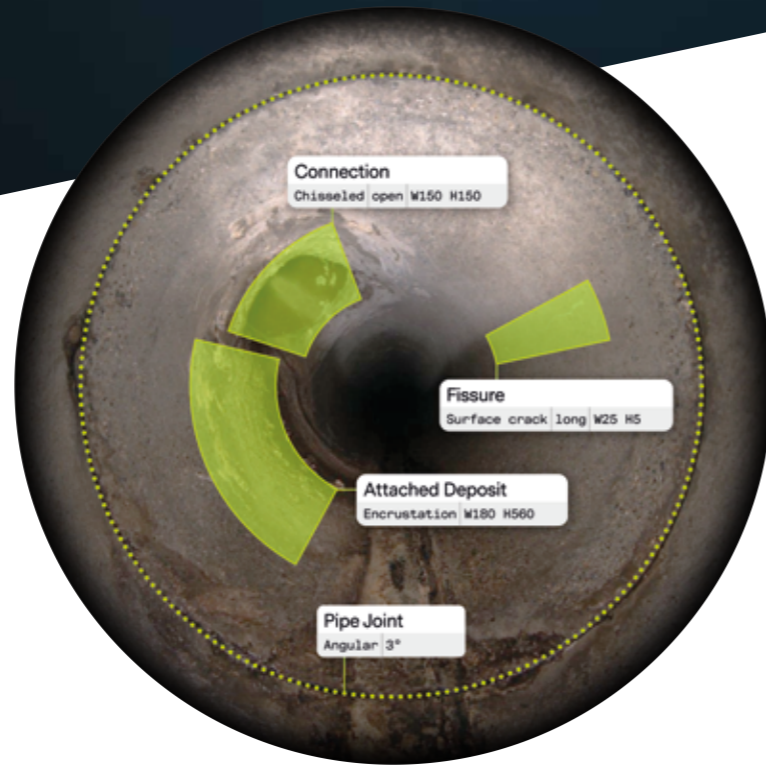

Workflow

Pallon integrates smoothly with your existing workflow. Upload your inspection footage and the corresponding metadata to our webapp, where we automatically report all defects and deliver you the results within days.



1. Inspect

Simply keep inspecting sewers as you've always been doing, just without coding the defects.

2. Upload

After inspecting a sewer, upload the inspection footage and the corresponding metadata to our web app.

3. Analyze

Once uploaded, we run our algorithms to detect, quantify and localize defects according to the coding standard of your choice.

4. Share

You get notified when the report, condition grading and photos are ready, so you can share them using our web viewer or just download them.

Technology

Pallon has developed cutting-edge deep neural networks and 3D vision algorithms that are capable of detecting, localizing, and measuring every single pipe defect.

Automatic detection

At the heart of our technology, deep neural networks are responsible for reliably detecting, localizing, and quantifying all defects in your sewer pipes. Our models are capable of distinguishing more than 300 main- and subclasses of defects, which enables the reporting of all damages required by the European, British, and US coding standards.

Our neural networks are trained on massive amounts of data: millions of images gathered in hundreds of different cities around the world.

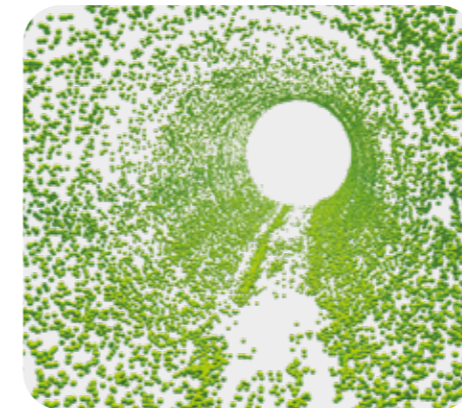

3D Vision

To accurately locate each detected defect in the real-world, we build a detailed 3D reconstruction of each pipe. Our state-of-the-art computer vision pipeline tracks hundreds of thousands of keypoints in pipe images to recover the position of the robot and the shape and structure of the pipe with millimeter precision.

To get the best possible view of the pipe, we have developed algorithms to automatically select the regions of the image with the best exposure and sharpness and crop out water drops on the lens.

What is supported

Pallon can analyze almost any kind of inspection footage of mainline sewers, laterals and manholes.

Drainage structures

- Mainline Sewers
- Lateral Sewers
- Manholes

Sewers types

Size:
100 – 2000mm

Material:
concrete / vitrified clay / plastic / brick / liner / other

Profile:
circular / egg-shaped / rectangular / other

Camera types

- Pan & tilt cameras
- Side scan cameras
- Satellite cameras
- Push cameras
- Drones

Norms and exchange formats

- DIN EN 13508-2: 2003 / 2011 (DWA-M 150, ISYBAU-XML)
- WRc (MSCC5)
- NASSCO (PACP 7)

Accessories



Camera centring for KS 60



PIN set for KS 60



Jetting nozzle



Pressure filling system



Deflection pulley



Folding rain and sun protection canopy



Radio remote control



SAT 42

I-Look

Shaft inspection in HD



Wireless manhole camera

- Camera in die-cast aluminium housing Protection class IP68
- Resolution HD: 1280 x 960 Pixel
- Sapphire lens camera
- Pressure monitoring
- Electric tilt 135°
- 20x optical zoom
- LED lighting
- Distance measure laser model
- Clutch for overload protection
- Camera hermetic seal
- Portable changeable lithium battery
- 7m / 10m / 12m carbon fiber telescopic pole
- 10" Tablet
- 64 GB memory card
- Charger
- Case for camera and tablet PC
- Accessories

DART SYSTEM

EXPERTISE KNOWLEDGE INNOVATION

Dart are specialist for the small and smaller pipe diameters and offer a huge product portfolio. When things get tight in the sewer pipe, Dart's inspection systems make their big appearance - from the smallest push system DX miCro with a 13mm head to the 25mm fixed or 26mm self-levelling camera heads of the Dart Eye Mini, up to the 36mm or 54mm cameras on the versatile DX push rod system. Many components are modular, making it possible to combine and interchange between products. Dart enables inspection of pipes, manholes and cavities, in buildings, for security and in industry. Every inspection area is unique, and Dart has the solution.



Pole Inspection Camera system

Available in 2.5m & 4m Lengths

The Pole Camera System is a portable rugged inspection system designed for the Utilities - Man Hole/Drain Inspection before descending or deploying fall arrest gear, Border Agencies, Security Industry, Utilities and Emergency Services. The Monitor can be Pole mounted or free-standing allowing the operator complete flexibility of movement whilst carrying out surveys, searches or surveillance.

- High Resolution Infra-Red camera head
- Articulation between 0° and 240°.
- Choice of Pole lengths 2.5m or 4m
- IP68 Rated
- 8hrs Battery Life



Cavity Inspection Camera system

Forward and Side View Probes

The Dart Cavity Inspection Camera will provide a high specification solution to Cavity Inspection. The system will allow for in-depth inspections and surveys of cavity wall voids with the capability to take high quality video & stills of the selected area. Suitable applications include Cavity Wall inspection, wall tie & dry rot inspection, pest control, boat surveys, Container inspections at port and many more where a rigid endoscope is required.

- Forward View or Side View Probes
- 5" LCD High resolution screen coated with an anti-glare coating
- 8hrs Battery life



miCro

Always with you

Small and compact: Designed to reach even the most difficult-to-reach places

The remote video inspection enables you to inspect even the tightest spaces therefore saving costly disassembles. Tubes, cavities, welding seams, turbines, hollow profiles and castings. At the same time, the cameras are so robust that they can easily withstand the harsh field conditions. In this way you locate all surface damages, cracks, sediments and deteriorations with minimal effort.

- Pipe diameter between 15 up to 80 mm
- Bends from 25 mm
- Colour camera head 13 mm
- Flexible push rod cable 15 m
- Sunlight-readable 5"-Display



Dart Viewer App

User interface of dart viewer app for recording of photos and videos including text generator.

Cameras



26mm

KK13

Axial 26mm diameter Self Levelling camera with high resolution camera module. For pipes from 30mm and larger. 10 bar waterproof.

Axial camera with high resolution colour camera module, Ø13 mm. For pipes 15 mm and larger. 1 bar waterproof.



36mm

KK18

Axial 36mm diameter Self Levelling camera with high resolution camera module. For pipes from 40mm and larger. 10 bar waterproof.

Axial camera with high resolution colour camera module, Ø18 mm. For pipes 25 mm and larger. 3 bar waterproof.



54mm

Axial 54mm diameter Self Levelling camera with high resolution camera module. For pipes from 60mm and larger. 10 bar waterproof.

Further information
dartsystems.
co.uk

WinCan Pro Touch.

• WinCan Pro Touch Compatible



DX Inspection System

50mm -300mm



DX Drain Inspection Camera System with 36mm diameter camera head. Choice of Rod lengths and large screen control panel allows the DX to be used for many applications with all aspects of pipes, drains and sewers.

- 36mm self-levelling camera head
- Optional 54mm self-levelling camera head
- 10.1" TFT display 1280 x 800 HD
- Built in location sonde
- Rod lengths 40m,60m, 80m or 120m (10.5mm dia)



The Dart Eye Mini is an ideal camera for domestic and light industrial pipe or sewer inspection and suited for pipes up to 150mm (6").

- 26mm self-levelling camera head
- Rod Lengths 30m or 45m (6.7mm dia)
- 7hrs battery life
- Built in location Sonde

Dart Eye Mini

30mm -150mm

RAUSCH REHAB SETTING NEW STANDARDS

They are the experts: the powerful high-tech cutter developed by Rausch Rehab, their new high-end UV curing system, and their innovative intensity measurement system for UV lamps are the pioneering solution for trenchless sewer rehabilitation at the highest standards. Rausch Rehab ensures that this standard always is maintained and controlled.

With in-depth technical instruction, the RRcure int02 intensity measuring case – first of its kind, in the world-scientifically accompanied development, that is applied all products, a redundant logging system, and backup of all system-specific data, with a customer account in the Cloud and with a manufacturer, that does independent system service. All out of one hand.

rausch

REHAB

UV Systems

UV curing systems

Intensity measurement kit RRcure INT02

- Suitable for construction sites
- Can measure all commercially available UV lamps
- Automatic measurement sequence
- Calibrated UV sensors (GaP & SiC)
- Supported by scientific research
- Internal memory
- Log output (pdf-cloud)
- (A) Direct measurement
- (B) (B) Indirect measurement via external UV system
- (C) Indirect measurement via adapter



Test option A
Absolute measurement by integrated electronic ballast, 400 to 1200 watts

Test option B
Measurement of the light source operated directly by the UV vehicle.



Test option C
Measurement of external emitters of UV cores

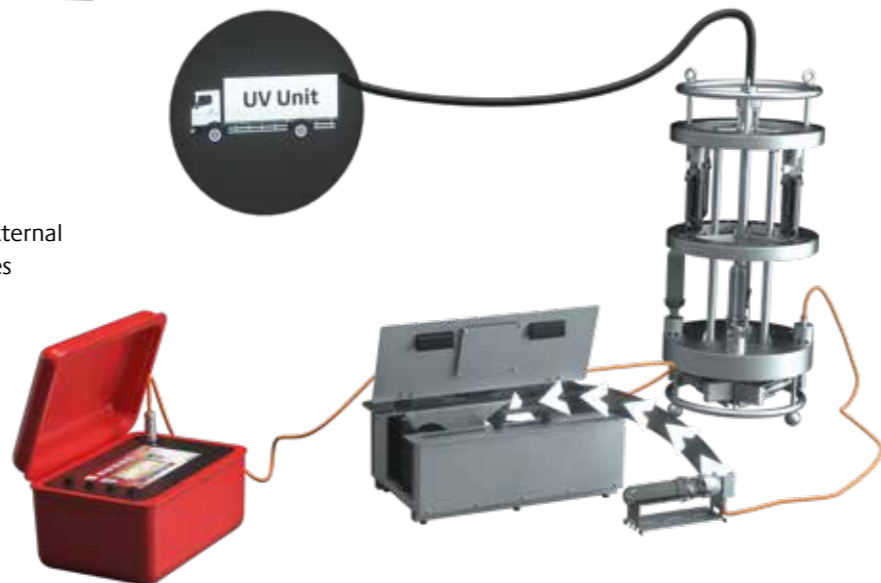

UV light-curing systems RRcure 100

- Version A**
- 6 x 400 watt
 - 150 m of cable
 - DN 100-300
 - As an add-on for existing facilities
 - Pipeline rehabilitation
 - Quality Assurance



RRcure 1500 Compact

- DN 150-1500
- 200 m / 23 mm
- 9 x 400 up to 2500 watt
- CEE 32 / 22 KW
- B/H/T - 850 mm / 1370 mm / 1600mm
- about 400 kg

- Version B**
- 6 x 1000 to 3000 watt
 - 2 x 1000 watt (base area)
 - 40 m of cable
 - Up to 2000 mm
 - Vertical manholes and structures
 - Pipeline rehabilitation
 - Quality assurance

RRcure 1000+ 2000

- Up to 5000 watt of power per emitter
- IR emitter (option)
- Adapted spectrum
- Remote control of the system
- Logging software
- Permanent installation - 300 m of cable
- Mobile systems up to 250 m of cable



LQ RRcure 150 - 600

- Plug-in front camera and horizontally self-aligning
- Horizontal position of the IR sensors is displayed
- 9 x 400 to 700 watt each per emitter
- DN 150-600 (also egg-shaped profile) (option - DN 100 -300)
- 2 x backeye camera

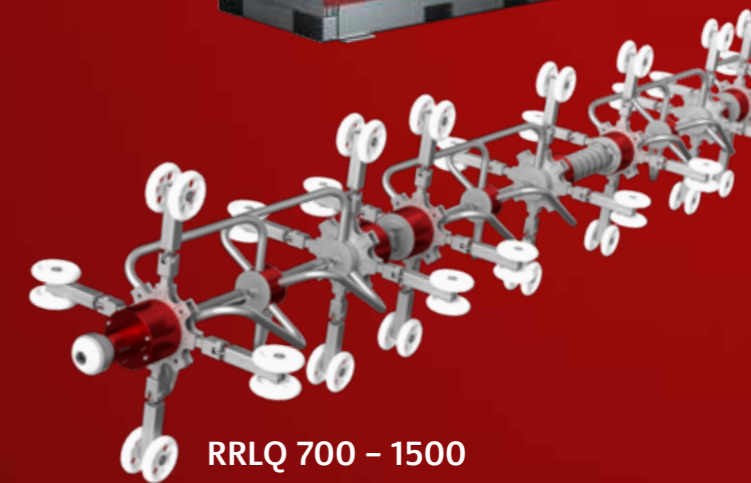

RRLQ 700 - 1500

- Radial light chain, DN 700-1500
- 9 x 1000 up to 2500 watt
- L = 4300 mm
- About 40 kg / without wheel set
- 350 mm / without wheel set

Robotic



Rausch-Tab: Central control unit

- Daylight-readable 12" touch display
- Integrated PC
- Robust aluminum housing
- Connection of two external joysticks
- Windows-based operating system

Cutter RRC1

- Full-HD camera
- DN 200 - DN 800
- Electric motor (power up to 2.5 kW)
- Endless arm rotation
- Rear view camera
- 4 degrees of freedom
- Modulare connections



Elektric motor RREM1

- Power up to 2.5 kW
- Speed of 8200 1/min
- Central locking
- Universal tool mounting



Camera RRV1 HD

- Full-HD resolution
- Endless panning of the head
- Cleaning function with scraper
- Integrated measurement laser
- Tool-free mounting and unmounting



Cable drum ELKA 600 RRC

- Fully automatic cable drum
- Up to 300 m of cable
- Integrated observation monitor
- Telescopic swivel arm with chain winch
- Working spotlight for manhole illumination
- Easy vehicle installation

Accessory



Wheels 200-800 mm



Adaption Top Hat



Camera extension



Adaption ultra high pressure nozzle

**RAUSCH
INTERNATIONAL
GROUP**

Rausch GmbH

Bruehlmoosweg 40
88138 Weissensberg
Tel. +49 8389 898-0
info@rauschtv.com
rauschtv.com

Dart Systems

Environment House,
Westfield Industrial Estate,
First Ave,
Radstock BA3 4BS
Tel. +44 (0) 1761 404870
sales@dartsystems.co.uk
dartsystems.co.uk

minCam GmbH

Konrad-Zuse-Str. 4
87509 Immenstadt
Tel. +49 8326 59567-00
info@mincam.de
mincam.de

Rausch Electronics USA, LLC.

1686 Opportunity Ave.
Chambersburg, PA 17201
Tel. +1 717 709-1005
sales@rauschusa.com
rauschusa.com

Rausch Rehab GmbH

Bruehlmoosweg 40
88138 Weissensberg
Tel. +49 8389 898-800
info@rausch-rehab.com
rausch-rehab.com